



Built to last



**Lightweight, corrosion-free and designed for performance**

# Hopper

Meeting the highest industry standards for food and pharmaceutical logistics

[www.saeplast.com](http://www.saeplast.com)

The ideal solution for storing and transporting bulk goods

The Hopper 1000 and 1800 are the ideal solution for storing and transporting eggs, ingredients, granulates, tablets and sauces. It is made from a one-piece moulded linear low-density polyethylene (LLDPE), approved for food use, is significantly lighter than conventional metal alternatives and completely corrosion resistant. With a large filling opening at the top (400mm wide) and an outlet at the bottom of up to 300mm, the Hopper ensures fast and efficient filling and dispensing.

The most important advantages:

- ✓ Large storage capacity with a small footprint
- ✓ Designed for use with forklift trucks and pallet trucks
- ✓ Maintenance-free and hygienic
- ✓ Intelligent and functional design
- ✓ Complete product discharge
- ✓ 60° cone prevents bridging

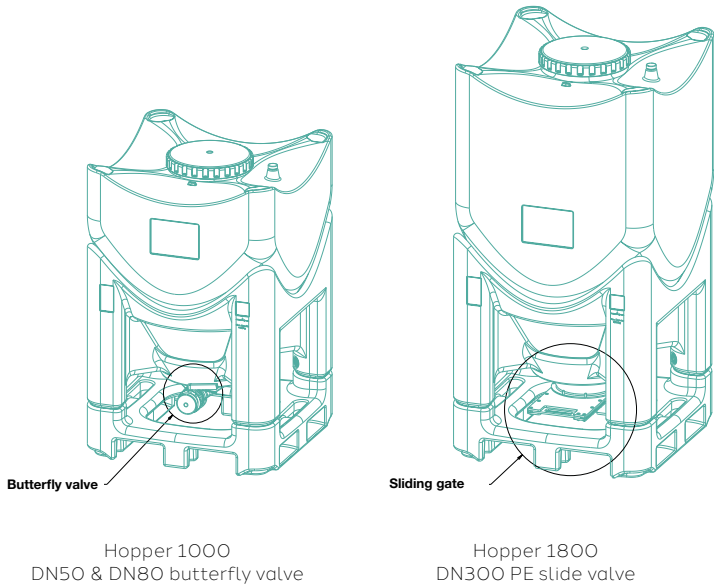

Hopper 1000  
DN50 & DN80 butterfly valve

Hopper 1800  
DN300 PE slide valve



DN300 Butterfly valve ss 316

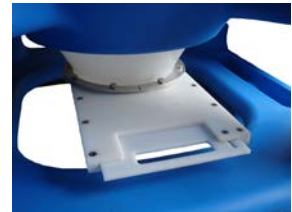

DN300 PE slide valve



DN300 butterfly valve stainless steel 304 with aluminium body



DN50 & DN80 butterfly valve ss 316

Technical Specifications

Model: Hopper 1000		Model: Hopper 1800	
Capacity	1000L (max. 1000kg)	Capacity	1800L (max. 1000kg)
Dimensions	1180 x 1180 x 1780 mm	Dimensions	1180 x 1180 x 2280 mm
Weight	165 kg	Weight	190 kg
Material	LLDPE	Material	LLDPE
Outlet Cone	60°	Outlet Cone	60°
Lid	400 mm, screw lid, sealable	Lid	400 mm, screw lid, sealable
Accessories	Labyrinth vent	Accessories	Labyrinth vent
Optional Colors			

Made from food-safe materials.



A part of rotovia